



CEQUENT™
CONSUMER PRODUCTS

**A Leader In
Commercial & Household
Cleaning Tools**

Cequent Consumer Products, Inc.
29000-2 Aurora Road, Solon, Ohio 44139
Cequent Help Hotline: 1-800-234-6992
Phone: 1-440-498-0001
Fax: 1-440-498-1038

Harper Brush
400 North 2nd Street, Fairfield, Iowa 52556
Phone: 1-800-500-9351
Fax: 641-472-3187

www.CequentConsumerProducts.com
www.HarperBrush.com
www.Laitner.com



AQUA-CLEAR™



FULTON



HARPER
— Est. 1900 —

**DURABILITY
PROS RELY ON**

Cequent Consumer Products, Inc. Reproduction of this catalog, or any part thereof, without the expressed permission of Cequent Consumer Products, Inc. is strictly prohibited.

Copyright 2013 - Pt. #26005-13 (Printed in U.S.A.)
All products & specifications subject to change without notice.

2013/14 CATALOG

Table of Contents

HARPER
EST. 1900

Push Brooms

Commercial Push Brooms	4-8
Assembled Push Brooms - Blue Line	9-11
Side-Clipped Push Brooms	12-18
Handle Extensions, Braces and Connectors ..	18-19
Replacement Tips	19

Long Handled Cleaning Tools

Corn Brooms	20-21
Angle and Upright Brooms	21-24
Floor Squeegees	25-28
Rakes	28
Long Reach Dusters	28

Utility Brushes

Counter Brushes	29-30
Utility Brushes	30-32
Scrub Brushes	32-33
Deck and Wall Brushes	33-35
Building Material Brushes	36-37
Wire Brushes	38
Miscellaneous Brushes	38-39

Mops

Wet Mops	40-44
Mop Buckets and Handles	45-46
Dust Mops	47-48

Wash Brushes

All Purpose Wash Brushes	49-51
Specialty Wash Brushes	52
Vehicle Cleaning Accessories	53
Microfiber Cloths and Mitts	54-55

Buckets and Dust Pans

Handles

Merchandisers and Displays

**DURABILITY
PROS RELY ON**

HARPER

— Est. 1900 —



Commercial and Industrial Cleaning Tools - Perfected for the Pro User



Push Brooms



Corn Brooms



Upright Brooms



Floor Squeegees



Counter Brushes



Utility Brushes



Scrub Brushes



Deck and Wall Brushes



Building Material Brushes



Wire Brushes



Cotton Mops



Sponge Mops



All Purpose Brushes



Specialty Brushes



Microfiber Cloths



Mitts



Buckets



Dust Pans

Commercial Push Brooms



All Harper® Red-End Push brooms have a slotted block that will accept a Harper bolt-on connector. Additional handles and accessories are sold separately.

Smooth to Semi-Smooth Surfaces



2218A

Item no.	Description
2218A	18" Assembled fine sweep indoor push broom
2224A	24" Assembled fine sweep indoor push broom

- Fine, split-tip synthetic bristles, 3" trim length
- Sweeps fine debris such as: dust, sand, wood shavings and light dirt from smooth and semi-smooth surfaces
- For indoor use under dry conditions such as body shops, offices, woodworking shops, warehouses, hospitals and household garages
- Assembled with 1 1/8" x 60" bolt-on connector handle and steel brace



Item no.	Description
3024	24" Fine to medium debris push broom head

- Split-tip synthetic bristles with two rows of steel wire center, 3" trim length
- Sweeps fine dust and heavier debris such as: drywall dust/debris, nails and wood shavings
- For indoor/outdoor use under dry conditions such as: new construction, remodeling and aggregate textured surfaces. Not for use on finished hardwood floors



3224

Item no.	Description
3224	24" Fine to medium debris Tampico push broom head
3236	36" Fine to medium debris Tampico push broom head
3224A	24" Assembled fine to medium debris Tampico push broom

- Natural, heat-resistant Tampico bristles, 2 7/8" trim length
- Sweeps medium debris such as: metal shavings, filings and industrial chemicals
- For indoor/outdoor use under dry conditions such as: foundries and welding shops. Especially suitable for high temperature surfaces or debris
- 3224A comes assembled with 1 1/8" x 60" bolt on connector handle and steel brace

Medium to Rough Surfaces

Item no.	Description
3424A	24" Assembled all purpose push broom

- Medium-stiff synthetic bristles center with fine, split-tip border bristles, 3" trim length
- Sweeps dust and mid-weight debris such as: dirt, dust, leaves and gravel
- For indoor/outdoor use under dry conditions on medium to rough surfaces such as asphalt, concrete or wood
- Assembled with 1 1/8" x 60" bolt-on connector handle and steel brace



Item no.	Description
3530A	30" Assembled medium to stiff push broom

- Medium-stiff synthetic bristle center with fine, split-tip border bristles, 3" trim length
- Sweeps dust and mid-weight debris such as: dirt, dust, leaves and gravel
- For indoor/outdoor use under dry conditions on medium to rough surfaces such as asphalt, concrete or wood
- Assembled with 1 1/8" x 60" bolt-on connector handle and steel brace



Item no.	Description
5424	24" Medium debris Tampico push broom head

- Two rows of steel wire bristles surrounded by natural, heat-resistant Tampico bristles, 2 7/8" trim length
- Sweeps medium and heavy debris such as: tough dirt, metal shavings, slag and other hot debris
- For indoor use under dry conditions such as: foundries, plastic factories, welding shops and aluminum plants



Item no.	Description
6724A	18" Assembled medium debris outdoor push broom

- Medium-stiff, solvent-resistant center, fine split-tip border bristles, 3" trim length
- Sweeps fine and medium debris such as: dust, light gravel, nails and metal shavings
- For outdoor use under dry conditions such as: driveways, sidewalks, asphalt, streets and warehouses
- Assembled with 1 1/8" x 60" bolt-on connector handle and steel brace



DURABILITY PROS RELY ON

Push Brooms

Long Handled Cleaning Tools

Utility Brushes

Mops

Wash Brushes

Buckets and Dust Pans

Handles

Harper's Red End push broom blocks are manufactured in the USA of kiln-dried hard maple. This attention to detail and the highest quality standards set our blocks apart from the competition. Look for our trademarked painted push broom head ends – when you see RED you are guaranteed a professional grade, durable product – Durability Pros Rely On.

Rough Surfaces



Item no.	Description
7124	24" Palmyra street debris push broom head

- Natural Palmyra bristles, 3 7/8" trim length
- Sweeps heavy debris such as: gravel, glass, light snow and shingle scraps
- For indoor/outdoor use under wet or dry conditions such as: streets, parking lots, machine shops and driveways

Semi-Smooth to Rough Surfaces



Item no.	Description
7318A	18" Assembled multi-surface push broom
7324A	24" Assembled multi-surface push broom

- Medium-stiff, solvent-resistant synthetic bristles, 3 1/8" trim length
- Sweeps heavy debris such as: oil dry, dirt/soil, wood scraps and nails
- For indoor/outdoor use under wet or dry conditions such as: job sites, fertilizer plants, grain elevators, patios, driveways and parking lots
- Assembled with 1 1/8" x 60" bolt-on connector handle and steel brace

Rough Surfaces

Item no.	Description
7924	24" Street debris push broom head
7924A	24" Assembled street debris push broom
7924AS	24" Assembled street debris push broom with scraper

- Stiff synthetic bristles, 3 1/8" trim length
- Sweeps heavy debris such as: mulch, heavy gravel, oil dry, nails and dirt/soil
- For outdoor use under wet or dry conditions such as: job sites, grain elevators, fertilizer plants and landscaping
- 7924A and 7924AS comes assembled with 1 1/8" x 60" bolt-on connector handle and steel brace



Item no.	Description
9316	16" Street debris push broom head with conventional tapered handle hole, no red ends
9318	18" Street debris push broom head with conventional tapered handle hole, no red ends
9418	18" Street debris push broom head
9424	24" Street debris push broom head
9424A	24" Assembled street debris push broom with conventional tapered handle hole

- Stiff, solvent-resistant synthetic bristles, 4 1/8" trim length
- Sweeps heavy debris such as: gravel, wet grass, mulch and heavy dirt
- For outdoor use under wet or dry conditions such as: street departments, landscaping, roofing job sites and heavy farm use
- 9424A comes assembled with 1 1/8" x 60" bolt-on connector handle and steel brace

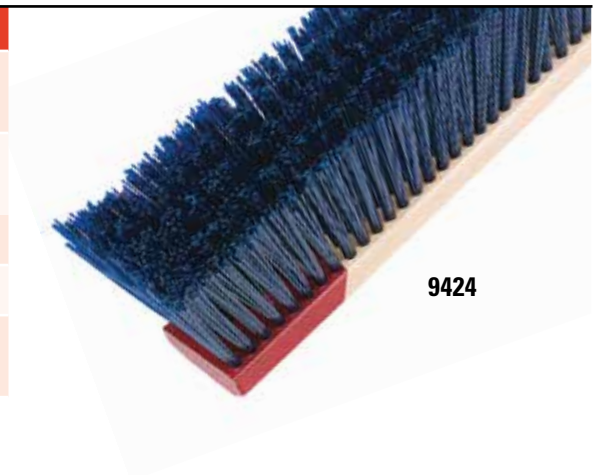

Item no.	Description
9616	16" Street debris push broom head
9616SC	16" Street debris push broom head with 1 1/8" x 60" lacquered handle, side clipped to a wood block, chipboard sleeve packaging with UPC code
9618	18" Street debris push broom head

- Stiff synthetic, safety orange bristles, 4 1/8" trim length
- Sweeps heavy debris such as: gravel, mulch and heavy dirt
- For outdoor use under wet or dry conditions such as: street departments, roofing job sites and landscaping

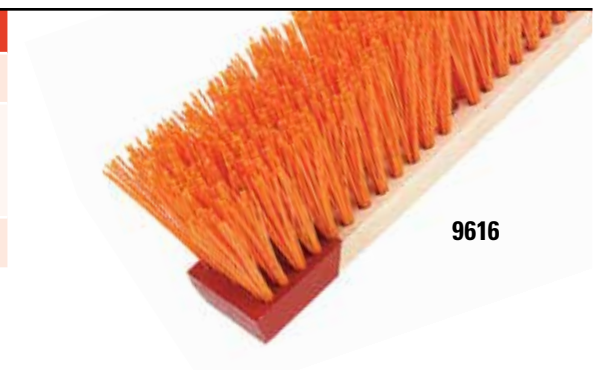

Rough Surfaces

9716



Tapered wood block accepts any standard tapered handle

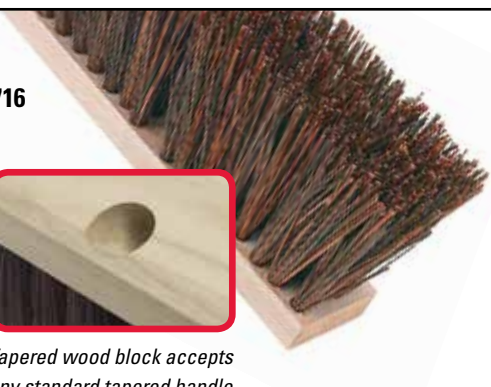

Item no.	Description
9716	16" Natural street debris push broom head
9716SC	16" Natural street debris side clipped with a 1 1/8" x 60" tapered wood handle, chipboard sleeve packaging with UPC code

- Stiff, natural African Bass bristles, 6 1/4" trim length
- Sweeps heavy debris such as: mulch, heavy dirt and gravel
- For outdoor use under wet or dry conditions such as: street departments, roofing job sites and landscaping



Item no.	Description
9816A	16" Assembled stiff synthetic safety orange street broom

- Extra-stiff, crimped safety orange synthetic bristles, 6 1/4" trim length
- Sweeps heavy debris such as: mulch, heavy dirt and gravel
- For outdoor use under wet or dry conditions such as: street departments, roofing job sites and landscaping
- Assembled with 1 1/8 x 60" tapered lacquered handle and steel brace

9916



Item no.	Description
9916	16" Extra stiff street debris push broom head
9916A	16" Assembled extra stiff street debris push broom

- Extra-stiff, crimped brown synthetic bristles, 6 1/4" trim length
- Sweeps heavy debris such as: mulch, heavy dirt and gravel
- For outdoor use under wet or dry conditions such as: street departments, roofing job sites and landscaping
- 9916A comes assembled with 1 1/8 x 60" tapered lacquered handle and steel brace

Assembled Push Brooms – Blue Line

Harper’s Blue Line is manufactured and packaged specifically for retail sales. Product labels help consumers choose the right bristles for the surface and debris being cleaned.

Smooth to Semi-Smooth Surfaces

Item no.	Description
552218A	18" Assembled fine debris indoor push broom
552224A	24" Assembled fine debris indoor push broom

- Fine, split-tip synthetic bristles, 3" trim length
- Sweeps fine debris such as: dust, sand, wood shavings and light dirt
- For indoor use under dry conditions such as: body shops, offices, woodworking shops, warehouses, hospitals and household garages
- Assembled with 1 1/8" x 60" bolt-on connector handle and steel brace



Item no.	Description
553024A	24" Assembled fine debris push broom with steel center

- Fine, split-tip synthetic bristles with two rows of steel wire center, 3" trim length
- Sweeps fine dust and heavier debris such as: drywall dust/debris, nails and wood shavings
- For indoor/outdoor use under dry conditions such as: new construction remodeling and aggregate textured surfaces. Not for use on finished hardwood floors
- Assembled with 1 1/8" x 60" bolt-on connector handle and steel brace



Medium to Rough Surfaces



553124A

Item no.	Description
553118A	18" Assembled medium debris push broom
553124A	24" Assembled medium debris push broom
553130A	30" Assembled medium debris push broom

- Medium-stiff synthetic center with fine, split-tip border bristles, 3" trim length
- Sweeps dust and mid-weight debris such as: dirt, dust, leaves and gravel
- For indoor/outdoor use under dry conditions such as asphalt, concrete or wood
- Assembled with 1 1/8" x 60" bolt-on connector handle and steel brace



Item no.	Description
553224A	24" Assembled Tampico push broom

- Natural, heat-resistant Tampico bristles, 2 7/8" trim length
- Sweeps medium debris such as: metal shavings, filings and industrial chemicals
- For indoor/outdoor use under dry conditions such as: foundries and welding shops
- Assembled with 1 1/8" x 60" bolt-on connector handle and steel brace



557624A

Item no.	Description
557618A	18" Assembled medium debris wet or dry use push broom
557624A	24" Assembled medium debris wet or dry use push broom

- Medium-stiff synthetic bristles, 2 7/8" trim length
- Sweeps medium to heavy debris such as: dirt/soil, wood scraps and nails
- For indoor/outdoor use under wet or dry conditions such as: asphalt or concrete
- Assembled with 1 1/8" x 60" bolt-on connector handle and steel brace

Medium to Rough Surfaces

Item no.	Description
557918A	18" Assembled heavy debris push broom
557924A	24" Assembled heavy debris push broom
557930A	30" Assembled heavy debris push broom

- Stiff synthetic bristles, 3 1/8" trim length
- Sweeps heavy debris such as: mulch, heavy gravel, oil dry, nails and dirt and soil
- For outdoor use under wet or dry conditions such as: job sites, grain elevators, fertilizer plants and landscaping
- Assembled with 1 1/8" x 60" bolt-on connector handle and steel brace



Item no.	Description
559024A	24" Assembled heavy debris push broom
559024AS	24" Assembled heavy debris push broom with metal scraper

- Stiff synthetic bristles, 4 1/8" Trim Length
- Sweeps heavy debris such as: mulch, heavy gravel, oil dry, nails and dirt and soil
- For outdoor use under wet or dry conditions such as: job sites, grain elevators, fertilizer plants and landscaping
- Assembled with 1 1/8" x 60" bolt-on connector handle and steel brace



Traditional Threaded Wood Block Push Brooms



Harper® has designed the traditional threaded wood block line for the customer who values quality and durability, while wishing to maintain traditional screw-in connection which fits any standard Acme threaded handle. Handles and accessories sold separately, except when noted.

Smooth Surfaces



Item no.	Description
581918-1	18" Horsehair blend push broom head
581924-1	24" Horsehair blend push broom head

- Premium Horsehair and synthetic blend bristles, 2 7/8" trim length
- Sweeps fine dust and light dirt from smooth and semi-smooth surfaces. Also feathers wet concrete
- For indoor/outdoor use in dry conditions such as: tile, marble and smooth concrete
- Chipboard sleeve package with UPC code for retail

Smooth to Semi-Smooth Surfaces



Item no.	Description
582218	18" Indoor push broom head
582218SC	18" Indoor side-clipped with a 15/16" x 60" threaded metal-tip wood handle, chipboard sleeve packaging with UPC code
582224	24" Indoor push broom head
582224SC	24" Indoor side-clipped with a 15/16" x 60" threaded metal-tip wood handle, chipboard sleeve packaging with UPC code
582236	36" Indoor push broom head

- Fine, split-tip synthetic bristles, 3" trim length
- Sweeps fine debris such as: dust, sand and wood shavings
- For indoor use, under dry conditions such as: offices, warehouses, hospitals, churches and household garages

Medium to Rough Surfaces

Item no.	Description
583118SC	18" All purpose push broom, chipboard sleeve packaging with UPC code
583124SC	24" All purpose push broom, chipboard sleeve packaging with UPC code
583124A-1	24" All purpose assembled with 15/16" x 60" metal handle and steel brace

- Medium-stiff synthetic center bristles with fine split-tip border, 3" trim length
- Sweeps dust and mid-weight debris such as: dirt, dust, leaves and gravel
- For indoor/outdoor use under dry conditions such as: asphalt, concrete or wood
- 583118SC and 583124SC come with 15/16" x 60" threaded metal tip wood handle side-clipped to wood block



583124A-1

Item no.	Description
583218	18" Tampico push broom head
583218-1	18" Tampico push broom head with chipboard sleeve packaging with UPC code
583224	24" Tampico push broom head
583224-1	24" Tampico push broom head with chipboard sleeve packaging with UPC code
583236	36" Tampico push broom head

- Natural, heat-resistant Tampico bristles, 2 7/8" trim length
- Sweeps medium debris such as: metal shavings, filings and industrial chemicals
- For indoor/outdoor use under dry conditions such as: foundries and welding shops
- Especially suitable for high-temperature surfaces or debris



583224



583524

Semi-Smooth Surfaces

Item no.	Description
583518	18" Medium duty push broom head
583524	24" Medium duty push broom head

- Heavy synthetic center with fine split-tip border bristles, 3" trim length
- Sweeps dust and mid-weight debris such as: leaves, sweeping compound and light gravel
- For indoor/outdoor use under dry conditions such as: driveways, sidewalks, parking lots, warehouses and patios

Semi-Smooth to Rough Surfaces

Item no.	Description
1143	14" Palmyra push broom head
1143SC-7	14" Palmyra push broom head side-clipped with a 15/16" x 54" threaded metal handle, chipboard sleeve packaging with UPC code
1183	18" Palmyra push broom head
1183SC-7	18" Palmyra push broom head side-clipped with a 15/16" x 60" threaded metal tip wood handle, chipboard sleeve packaging with UPC code
1243SC-7	24" Palmyra push broom head side-clipped with a 15/16" x 60" threaded metal tip wood handle, chipboard sleeve packaging with UPC code
587124A-1	24" Assembled Palmyra push broom

- Natural Palmyra bristles, 3" trim length
- Sweeps heavy debris such as: gravel, glass and shingle scraps
- For indoor/outdoor use under wet or dry conditions such as: streets, parking lots and driveways
- 587124A-1 comes assembled with 15/16" x 60" threaded metal handle and steel brace



587124A-1

Medium to Rough Surfaces

Item no.	Description
587618	18" Wet or dry use push broom head
587624	24" Wet or dry use push broom head
587636	36" Wet or dry use push broom head

- Medium-stiff synthetic bristles, 3" trim length
- Sweeps heavy debris such as: oil dry, dirt/soil, wood scraps and nails
- For indoor/outdoor use under wet or dry conditions such as: job sites, fertilizer plants, grain elevators, patios, driveways and parking lots



587624

Rough Surfaces

Item no.	Description
587918	18" Outdoor push broom head
587918SC	18" Outdoor push broom head side clipped with a 15/16" x 60" threaded metal-tip wood handle, chipboard sleeve packaging with UPC code
587924	24" Outdoor push broom head
587924SC	24" Outdoor push broom head side clipped with a 15/16" x 60" threaded metal-tip wood handle, chipboard sleeve packaging with UPC code
587936	36" Stiff push broom head

- Stiff synthetic bristles, 3 1/8" trim length
- Sweeps heavy debris such as: mulch, heavy gravel, oil dry, nails and dirt/soil
- For outdoor use under wet or dry conditions such as: job sites, grain elevators, fertilizer plants and landscaping

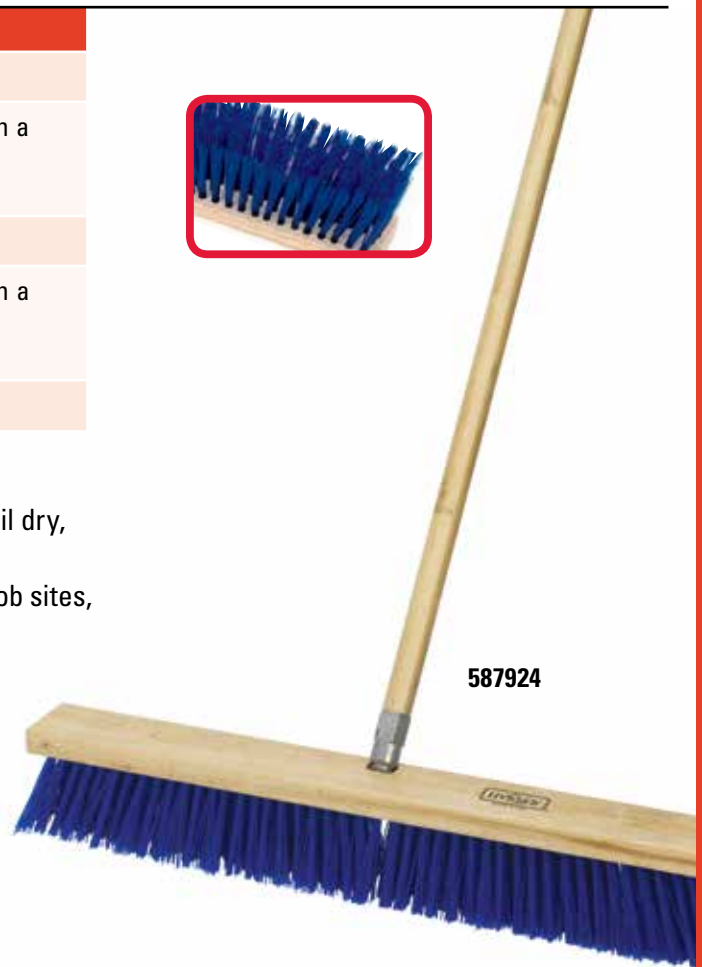

587924

Medium to Rough Surfaces



589624A

Item no.	Description
589618	18" Stiff outdoor push broom head
589624	24" Stiff outdoor push broom head
589624A	24" Assembled stiff outdoor push broom

- Stiff synthetic, safety orange bristles, 4 1/8" trim length
- Sweeps heavy debris such as: gravel, mulch and heavy dirt
- For outdoor use under wet or dry conditions such as: street departments, roofing job sites and landscaping
- 589624A comes assembled with 15/16" x 60" threaded metal-tip wood handle and steel brace



Threaded plastic block accepts any standard threaded handle.

1524A-1

1524SC-1

Item no.	Description
H1524	24" All purpose squeegee push broom head
1524A-1	24" Assembled all purpose squeegee push broom
1524SC-1	24" All purpose squeegee side clipped with a 15/16" x 60" threaded metal handle, chipboard sleeve packaging with UPC code

- Medium-stiff synthetic center bristles with fine split-tip border, 3" trim length
- Push broom plus squeegee. Two tools in one!
- Sweeps dirt, dust, leaves and gravel, as well as moves liquids.
- For indoor/outdoor use under wet/dry conditions on asphalt, concrete or wood surfaces
- 1524A-1 comes assembled with 15/16" x 60" metal handle and steel brace

Products listed below for Side-Clipped push brooms with 18" blocks come with a 54" metal handle. 24" blocks come with a 60" metal handle.

Smooth Surfaces

Item no.	Description
682718SC	18" Side-clipped indoor push broom
682724SC	24" Side-clipped indoor push broom

- Split-tip synthetic bristles, 3 1/2" trim length
- Indoor use
- Structural resin block
- Best for: dust, sand, wood shavings
- Chipboard sleeve packaging with UPC code



Multi-Surface

Item no.	Description
152518SC	18" Side-clipped all purpose squeegee push broom
1525SC	24" Side-clipped all purpose squeegee push broom

- Synthetic blend bristles, 3 1/2" trim length
- Indoor/outdoor use
- Structural resin block
- Rubber squeegee
- Best for: wet or dry dirt and liquid spills
- Chipboard sleeve packaging with UPC code



Item no.	Description
683318SC	18" Side-clipped all purpose push broom
683324SC	24" Side-clipped all purpose push broom

- Synthetic blend bristles, 3 1/2" trim length
- Indoor/outdoor use
- Structural resin block
- Best for: dirt, light gravel, leaves
- Chipboard sleeve packaging with UPC code



Rough Surfaces



Item no.	Description
687118SC	18" Side-clipped outdoor push broom
687124SC	24" Side-clipped outdoor push broom

- Natural Palmyra bristles, 3 1/2" trim length
- Outdoor use
- Structural resin block
- Best for: gravel, mulch, dirt
- Chipboard sleeve packaging with UPC code



Item no.	Description
688018SC	18" Side-clipped outdoor push broom
688024SC	24" Side-clipped outdoor push broom

- Stiff synthetic bristles, 3 1/2" trim length
- Outdoor use
- Structural resin block
- Best for: gravel, mulch, dirt
- Chipboard sleeve packaging with UPC code

Handle Extension



Item no.	Description
379144H	6' to 12' Handle extension

- Aluminum
- Pin-lock
- Threaded metal tip

Braces



Item no.	Description
H86	16" Push broom brace, standard pk of 24
H87	18" to 36" Push broom brace, standard pk of 48
87-1	18" to 36" Push broom brace, standard pk of 12
H89	42" Push broom brace, standard pk of 12

- Powder-coated metal

Connectors

Item no.	Description
84D	For use with all Harper slotted blocks, sturdy steel construction with reinforced ribs
85PC	Synthetic resin connector

84D



Replacement Tips

Item no.	Description
901T	Plastic threaded tip, fits 15/16" - 1 1/8" handle
910T	Plastic threaded tip, acid-resistant, fits 1" - 1 1/8" handle
912T	Metal threaded tip, fits 15/16" - 1 1/8" handle
915T	Zinc threaded tip, fits fiberglass extension handles



901T



910T



912T



915T

Sweeping Compound

Item no.	Description
70350	Red sweeping compound, hard, clean and dry angular silica sand is added, ideal for unfinished floors such as wood and concrete

- 50 lb.



No matter the dirt or debris,
Harper has a push broom to
get the job done

Long Handled Cleaning Tools

Corn Brooms



Item no.	Description
100	Professional/Contractor corn broom

- 100% Corn fiber
- 1-wire
- 4-sew
- 1 1/8" x 42" Wood handle, red painted tip
- Meets ASTM International standards



Item no.	Description
100-2	Multi-Purpose corn broom

- 100% Corn fiber
- 1-wire
- 4-sew
- 1 1/8" x 42" Wood handle, blue painted tip
- Meets ASTM International standards



Item no.	Description
100L	Lobby corn broom

- 100% Corn fiber
- 3-sew
- 3/4" x 30" Wood handle, 38" overall length



Item no.	Description
1327	Household corn broom

- Natural bristles
- 3-sew
- 7/8" x 42" Wood handle



Item no.	Description
1329	Janitor corn broom

- Natural bristles
- 5-sew
- 1 1/8" x 42" Wood handle

Corn Brooms

Item no.	Description
1330	Warehouse corn broom

- Natural bristles
- 3-sew
- 1-wire
- 1 1/8" x 42" Wood handle



Upright Brooms

Item no.	Description
105-1	9" Beige, wood block with vinyl bumper
105-3	9" Blue, wood block with vinyl bumper
105-4	9" Grey, wood block with vinyl bumper
10516A-1	9" Beige, assembled with 7/8" x 48" metal handle
10516A-4	9" Grey, assembled with 7/8" x 48" metal handle
108-1	12" Beige wood block version with vinyl bumper
108-3	12" Blue wood block version with vinyl bumper
108-4	12" Grey wood block version with vinyl bumper
10804A	12" Grey, assembled with 7/8" x 48" metal handle, chipboard sleeve packaging with UPC code

- Split-tip synthetic bristles, 4" trim length
- Threaded handle hole, 90° angle
- Ideal for kitchens, utility rooms, offices, beauty and barber shops



Upright Brooms



Item no.	Description
109	9" Wood block upright broom
112	12" Wood block upright broom
11202A	12" Assembled upright broom with 7/8" x 48" metal handle

- Stiff synthetic bristles, 4" trim length
- Threaded handle hole, 90° angle
- Ideal for grain elevators, mills, factories, sidewalks and foundries
- Solvent resistant, not affected by most petroleum products

Upright and Angle Brooms



Item no.	Description
110	9" Wood block blended upright broom

- Mixture of fine and medium-stiff synthetic bristles, 4" trim length
- Threaded handle hole, 45° angle
- Ideal for sweeping under bus, theater and restaurant seats



Item no.	Description
111	9" Wood block fine upright broom, 4" trim
117	9" Wood block fine upright broom, 3" trim

- Fine, split-tip synthetic bristles
- Threaded handle hole, 45° angle
- Ideal for sweeping under bus, theater and restaurant seats

Upright and Angle Brooms

Item no.	Description
115-1	9" Beige, wood block, angle broom with vinyl bumper
115-3	9" Blue, wood block, angle broom with vinyl bumper
115-4	9" Grey, wood block, angle broom with vinyl bumper
115-4A	9" Assembled grey, angle broom with 7/8" x 48" metal handle
118-1	12" Beige, wood block angle broom version
118-3	12" Blue, wood block angle broom version
118-4	12" Grey, wood block angle broom version



- Fine, split-tip synthetic bristles, tapered 4" to 3" trim length
- Threaded handle hole, 90° angle
- Ideal for kitchens, utility rooms, offices, beauty and barber shops

Item no.	Description
4001	Angle broom with 6 1/2" plastic cap, trim length tapered 5" to 4"
4040	Angle broom with 9" plastic cap, trim length tapered 8" to 6"



- Fine, split-tip synthetic bristles
- 54" overall length
- 7/8" x 47" Plastic handle with hang-up swivel cap
- Ideal for light-duty jobs

Item no.	Description
4042	Large angle broom and whisk broom in one



- Fine, split-tip synthetic bristles, 4 1/2" to 4" trim length
- 54" Overall length
- 7/8" x 48" Metal handle with hang-up cap
- Ideal for kitchens, bathrooms and foyers

Upright and Angle Brooms



Item no.	Description
4043	Jumbo angle broom

- Medium, split-tip synthetic bristles, tapered 7" to 6" trim length
- 54" Overall length
- 7/8" x 48" Metal handle with hang-up cap
- Ideal for kitchens, bathrooms, foyers and garages



Item no.	Description
4045	Professional large angle broom
4045-480	Professional large angle broom with 12" plastic dustpan clipped to handle

- Stiff, split-tip synthetic bristles, tapered 7" to 5 1/2" trim length
- 54" overall length
- 15/16" x 48" Metal handle with hang-up cap
- Ideal for hardwood floors, tile, linoleum and smooth concrete
- Packaged with UPC code for retail



Item no.	Description
4045L	Synthetic lobby broom

- Split-tip bristles for fine dust
- 3/4" x 30" Metal handle, 38" overall length



Item no.	Description
4046	All purpose angle broom

- Stiff, split-tip recycled synthetic bristles, 7" – 5 1/2" trim length
- 48" Threaded handle with hang-up cap, 54" overall length
- For indoor/outdoor use under dry conditions on smooth to semi-smooth surfaces



Item no.	Description
471012	12" Upright broom with foam block

- Mixture of fine and medium-stiff synthetic bristles, 3 1/8" trim length
- Foam block made from recycled plastic
- Threaded handle hole, 90° angle
- Ideal for use in the food industry where wood blocks are not accepted

Squeegee blades are firmly anchored between heavy-gauge, powder-coated steel strips secured by plated 1/4" bolts. Handles and accessories sold separately.

Floor Squeegees

Item no.	Description
24724	24" Curved double-edge rubber squeegee
24824R	Replacement, refill blades for 24724
24730	30" Curved double-edge rubber squeegee
24830R	Replacement, refill blades for 24730
H24736	36" Curved double-edge rubber squeegee
24836R	Replacement, refill blades for 24736



24724

- Rubber blade, 1/4" thick x 3 1/2" wide
- Effectively cleans heavy debris on all types of surfaces
- Curved ends enhance debris containment

Item no.	Description
H24818	18" Double-edge rubber squeegee
24818R	Replacement, refill blades for H24818
H24824	24" Double-edge rubber squeegee
24824R	Replacement, refill blades for H24824
H24830	30" Double-edge rubber squeegee
24830R	Replacement, refill blades for H24830
H24836	36" Double-edge rubber squeegee
24836R	Replacement, refill blades for H24836



H24824

- Rubber blade, 1/4" thick x 3 1/2" wide
- Effectively cleans heavy debris on all types of surfaces
- Reversible blades extend squeegee life

Item no.	Description
25524	24" Double-edge moss foam squeegee
25524R	Replacement, refill blades for 25524
25530	30" Double-edge moss foam squeegee
25530R	Replacement, refill blades for 25530
25536	36" Double-edge moss foam squeegee
25536R	Replacement, refill blades for 25536 and 25636
25636	36" Double-edge curved moss foam squeegee



25524

- Two moss foam blade, 3/8" thick x 3 1/2" wide
- Effectively cleans light and medium debris on smooth and semi-smooth surfaces
- Two reversible blades extend squeegee life and provide quick-drying action

Floor Squeegees

Squeegee View



Item no.	Description
24224	21st Century Powrwave® floor squeegee
24224A-2	24" Assembled with 1 1/8" x 60" wood handle and steel brace with blue painted tip
5324224A	24" Assembled with 1 1/8" x 60" wood handle and steel brace, with red painted tip

24224A-2

- 24" rubber blade, 1/4" x thick x 3 1/2" wide
- Powrwave® is the most effective advancement in wet conditions through its unique "fluid directional control." This lightweight, 24" gated squeegee moves as much fluid as a 36" curved squeegee. The directional gates make it 40% more effective than any other squeegee. The squeegee blade is firmly anchored between extra-strong plastic plates. Reversible squeegee rubber provides twice the life and use of a single-edge squeegee. Use Harper 248HAS handle and H81 brace to ensure distribution of load and shock
- Patented design



The patented PowrWave® Squeegee moves the most liquid

Floor Squeegees

Item no.	Description
2400	24" Single-edge floor squeegee

- Vinyl blade, 1/4" thick x 2" wide
- Effectively cleans heavy debris on all types of surfaces
- Heavy-duty, 14-gauge zinc plated steel frame
- Socket included, accepts tapered handles



Item no.	Description
C2400	24" Curved single-edge squeegee
C2400A	24" Assembled with 1 1/8" x 60" wood handle
C3600	36" Curved single-edge squeegee

- Vinyl blade, 1/4" thick x 2" wide
- Effectively cleans heavy debris on all types of surfaces
- Curved ends enhance debris containment
- Socket included, accepts tapered handles

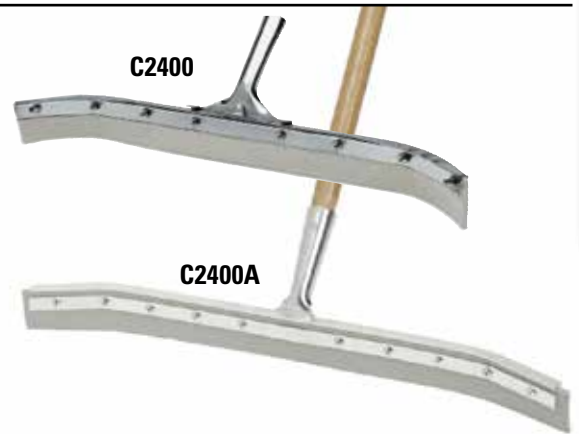

Item no.	Description
25018	18" Moss foam rubber squeegee

- Twin moss foam rubber blade, 3/8" thick x 1 1/2" wide
- Effectively cleans light and medium debris on smooth and semi-smooth surfaces
- Reversible blades extend squeegee life and provide quick-drying action
- Socket included, accepts tapered handles



Item no.	Description
25322	22" Moss foam rubber squeegee, 3/8" thick x 1 1/2" wide
25322A	22" Assembled with 15/16" x 54" wood handle
25330	30" Moss foam rubber squeegee, 3/8" thick x 2" wide

- Twin moss foam rubber blade
- Effectively cleans light and medium debris on smooth and semi-smooth surfaces
- Blades provide quick-drying action
- Socket included
- Recommended handle: 253H



Squeegee Connectors and Braces



Item no.	Description
H81	Squeegee brace, powder-coated metal
81-253	Brace for 25322 and 25330
240	Squeegee connector, powder-coated metal, angled for straight floor squeegees
240-45	Squeegee connector, durable metal alloy, angled for curved floor squeegees
241	Squeegee connector, durable plastic, angled for straight floor squeegees
243	Squeegee connector, durable plastic, angled for straight and curved floor squeegees, will not fit Harper Powrwave® floor squeegee

- Socket included
- Handles sold separately

Rakes



Item no.	Description
610	21" Wide Lawn/landscaping rake

- Polycarbonate head
- Includes 15/16" x 60" fiberglass handle

Long Reach Duster



Item no.	Description
H323	70" Long reach duster

- Duster for hard to reach areas
- 70" Telescopic handle



Item no.	Description
T926E	30" - 42" Natural lambs wool duster

- Duster for hard to reach areas
- Plastic handle
- Twist and lock extendable handle

Brushes

Counter Brushes

Item no.	Description
453	14" Horsehair counter brush

- Natural Horsehair bristles, 2 1/4" trim length
- 8" Sweeping face
- Wood block
- Ideal for fine debris on smooth surface



Item no.	Description
H454	14" Horsehair blend counter brush

- Natural Horsehair/synthetic blend bristles, 2 1/4" trim length
- 8" Sweeping face
- Wood block
- Ideal for fine debris



Item no.	Description
457-1	14" Synthetic counter brush

- Split-tip synthetic bristles, 2 1/4" trim length
- 8" Sweeping face
- Wood block
- Ideal for fine debris on wet or dry surfaces



Item no.	Description
457-4	14" Stiff synthetic counter brush

- Synthetic, stiff center and fine border bristles, 2 1/4" trim length
- 8" Sweeping face
- Wood block
- Ideal for medium debris on wet or dry surfaces



Item no.	Description
471	14" Synthetic counter brush

- Synthetic, stiff center and fine border, 2 1/4" trim length
- 8" Sweeping face
- Wood block
- Ideal for medium debris



Counter Brushes



Item no.	Description
H667	14" Plyer counter brush

- Plyer, blue bristles, 2 1/4" trim length
- 8" Sweeping face
- Plastic block
- Ideal for fine debris



Item no.	Description
656V	14" Stiff synthetic counter duster

- Stiff synthetic bristles, 2 7/8" Trim length
- Large sweeping face
- Plastic ergonomic handle
- Ideal for large debris



Item no.	Description
657V-4	14" Synthetic counter duster

- Split-tip synthetic bristles, 2 7/8" trim length
- Large sweeping face
- Plastic ergonomic handle
- Ideal for fine debris

Utility Brushes



Item no.	Description
221	8 1/2" Synthetic utility brush
231	20" Synthetic utility brush

- Soft synthetic bristles
- Raised handle with finger grooves
- Plastic block
- Ideal for light scrubbing



Item no.	Description
224	8 1/2" Nylon utility brush
234	20" Nylon utility brush

- Crimped nylon Bristles
- Raised handle with finger grooves
- Plastic block
- Ideal for medium scrubbing

Utility Brushes

Item no.	Description
226	8 1/2" Stiff synthetic utility brush
236	20" Stiff synthetic utility brush

- Stiff synthetic bristles
- Raised handle with finger grooves
- Plastic block
- Ideal for heavy scrubbing



Item no.	Description
H281	8 1/2" Tampyl utility brush
291	20" Tampyl utility brush

- Acid-resistant tampyl bristles
- Raised handle with finger grooves
- Plastic block
- Ideal for medium scrubbing



Item no.	Description
282	8 1/2" Palmyra utility brush
292	20" Palmyra utility brush

- Natural Palmyra bristles
- Raised handle with finger grooves
- Plastic block
- Ideal for heavy scrubbing



Item no.	Description
283	8 1/2" Tampico utility brush

- Natural acid resistant Tampico bristles
- Raised handle with finger grooves
- Plastic block
- Ideal for medium scrubbing



Utility Brushes



Item no.	Description
284	9" PET utility brush
294	20" PET utility brush

- Fine, split-tip recycled PET synthetic bristles
- Raised handle with finger grooves
- Recycled polypropylene block
- Ideal for medium scrubbing

Scrub Brushes



Item no.	Description
132	3 Pack tile and grout brushes

- Synthetic bristles, 1/2" trim length
- Plastic block and handle
- Ideal for hard-to-reach areas



Item no.	Description
163	8" Tampico scrub brush

- Acid-resistant Tampico bristles, 1 1/4" trim length
- Wood block, one threaded 45° handle hole
- Ideal for cleaning decks, concrete and masonry



Item no.	Description
166	6" Curved scrub brush

- Crimped synthetic bristles, 1 1/2" trim length
- Plastic, curved block
- Stiff bristles for tough scrubbing



Item no.	Description
179	8" Palmyra scrub brush

- Natural Palmyra bristles, 1 1/4" trim length
- Wood block, one threaded 45° handle hole
- Ideal for rough wet or dry surfaces

Scrub Brushes

Item no.	Description
180	9" Pointed-end scrub brush

- Synthetic bristles, 1" trim length
- Plastic block with finger grooves
- Hanging hole for easy storage



Item no.	Description
182	9" Pointed-end scrub brush

- Acid-resistant Tampico bristles, 1" trim length
- Wood block
- Grooved edges for secure grip



Item no.	Description
601	4 3/4" Hand and nail brush

- Synthetic bristles, 1" trim length
- Wood block
- 4 1/2" x 1" Scrubbing face



Item no.	Description
NBHW-0007	4" Synthetic Iron Handle Hand & Nail Brush

- Raised handle brush
- Plastic block and handle
- Protects hands and knuckles while cleaning



Deck and Wall Brushes

Item no.	Description
325	8" Assembled deck brush with handle

- Synthetic, blue bristles, 1" trim length
- Plastic block, threaded hole
- 7/8" x 48" Metal handle



Deck and Wall Brushes

561912A



Item no.	Description
561912A	12" Assembled deck brush with blue tip handle
53561912A	12" Assembled deck brush with red tip handle

- Stiff synthetic bristles, 2" trim length
- Hardwood block, slotted for bolt-on connector
- 1 1/8" x 60" wood bolt-on handle
- Ideal for scrubbing decks and concrete



Item no.	Description
690210A	10" Assembled deck brush with handle

- Synthetic bristles, 1" trim length
- Plastic block, threaded hole
- 15/16" x 54" Metal handle

NBID-0055



Item no.	Description
NBID-0005	10" Palmyra block brush
NBID-0055	12" Palmyra block brush

- Natural Palmyra bristles, 2" trim length
- One tapered and one threaded handle hole
- Hardwood block
- Ideal for heavy-duty scrubbing on rough surfaces

NBID-0026

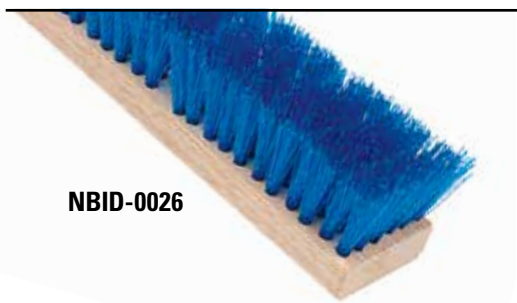

Item no.	Description
NBID-0006	10" Synthetic block brush
NBID-0026	12" Synthetic block brush

- Crimped synthetic bristles, 2" trim length
- One tapered and one threaded handle hole
- Synthetic bristles are impervious to most solvents

Deck and Wall Brushes

Item no.	Description
NBID-0025	10" Palmyra squeegee block brush

- Natural Palmyra bristles, 2" trim length
- One tapered and one threaded handle hole
- Hardwood block
- Squeegee secured by staples within groove of block



Item no.	Description
897510	10" Tri-level brush

- Stiff crimped synthetic bristles, 2 1/2" trim length
- Threaded handle hole
- Plastic block
- Block and bristle design allow for three distinct washing angles
- Ideal for scrubbing concrete, tile floors and walls



Cleaning tools for every surface,
every type of dirt and debris

DURABILITY PROS RELY ON



Items below are shipped in a cut case carton (19" x 9" x 7 1/4") with product description label unless otherwise noted. Handles sold separately, except where noted.

Building Material Brushes

157-14



Item no.	Description
157-14	7" Tampico roof coat brush, 14 in cut case
157SC-08	7" Side clipped Tampico roof coat brush with a 15/16" x 54" metal handle with threaded dura tip, 8 pieces per standard shipper box.

- Acid-resistant Tampico bristles, 2" trim length
- Wood block with threaded handle hole
- Ideal for applying roof coatings and sealants



Item no.	Description
163-21	8" Tampico scrub brush, 21 in cut case

- Acid-resistant, Tampico bristles, 1 1/4" trim length
- Heavy-duty wood block with threaded handle hole
- Ideal for scrubbing masonry, decks and concrete

426-18



Item no.	Description
426-18	18" Driveway sealant brush with squeegee, 18 in cut case
426SC-08	18" Side clipped with a 15/16" x 54" metal handle with threaded dura tip, 8 pieces per standard pack box.

426SC-08



- Natural Palmyra bristles, 2 1/8" trim length
- Heavy duty wood block with threaded handle hole
- Rubber squeegee



Item no.	Description
501T-14	6" 3-Knot roof brush, 14 in cut case

- Acid-resistant, natural Tampico bristles, 4" trim length
- Sturdy steel ferrules
- Heavy duty wood block with threaded handle hole

Building Material Brushes

Item no.	Description
547-8	Masonry brush, 8 in cut case

- Acid-resistant, natural Tampico bristles, 4" trim length
- Heavy-duty wood block with red handle
- Ideal for applying solutions and coatings



Item no.	Description
557-12	9" Tampico roof coat brush, 12 in cut case

- Acid-resistant, natural Tampico bristles, 2" trim length
- Wood block with threaded handle hole
- Fits 5-gallon buckets and pails



Item no.	Description
548CC	6 1/2" Masonry brush, 10 in cut case

- Acid-resistant, natural Tampico bristles, 4" trim length
- Plastic block with hang-up hole for easy storage
- Ideal for applying coatings



Item no.	Description
549CC	4 3/4" Masonry brush

- Crimped synthetic bristles, 2 1/2" to 3" trim length
- Plastic block with hang-up hole for easy storage
- Ideal for texture and stippling effects



Item no.	Description
36624	24" Cement finishing brush

- Soft nylon bristles, 2 1/2" trim length
- Wood block, two threaded handle holes
- Rinses quickly and easily



Wire Brushes



Item no.	Description
524	14" Wire scratch brush

- Wire bristles, 1" trim length
- Curved wood block
- 3 x 19 Rows



Item no.	Description
5242	7" Wire brush

- Wire bristles, 1 1/2" trim length
- Wood block
- 6 x 19 Rows



Item no.	Description
NBID-0009	14" Wire scratch brush with scraper

- Wire bristles, 1" trim length
- Wood block
- 3 x 19 Rows

Miscellaneous Brushes



Item no.	Description
340	8" Window brush

- Tampyl bristles, 2 1/2" trim length
- Wood block with threaded handle hole
- Ideal for any glass surface



Item no.	Description
595	Boot brush

- Synthetic bristles, 2 1/2" trim length
- Designed to clean front, back and side of shoe and boots
- Brushes flip over to expose steel scraper bar

Miscellaneous Brushes

Item no.	Description
576	12" BBQ brush with metal scraper

- Crimped stiff brass bristles, 3/8" trim length
- Plastic block and handle with hang-up hole for easy storage



Item no.	Description
578	20" Crimp brass BBQ brush with handle grip

- Crimped stiff brass bristles, 3/8" trim length
- Plastic block and handle with hang-up hole for easy storage

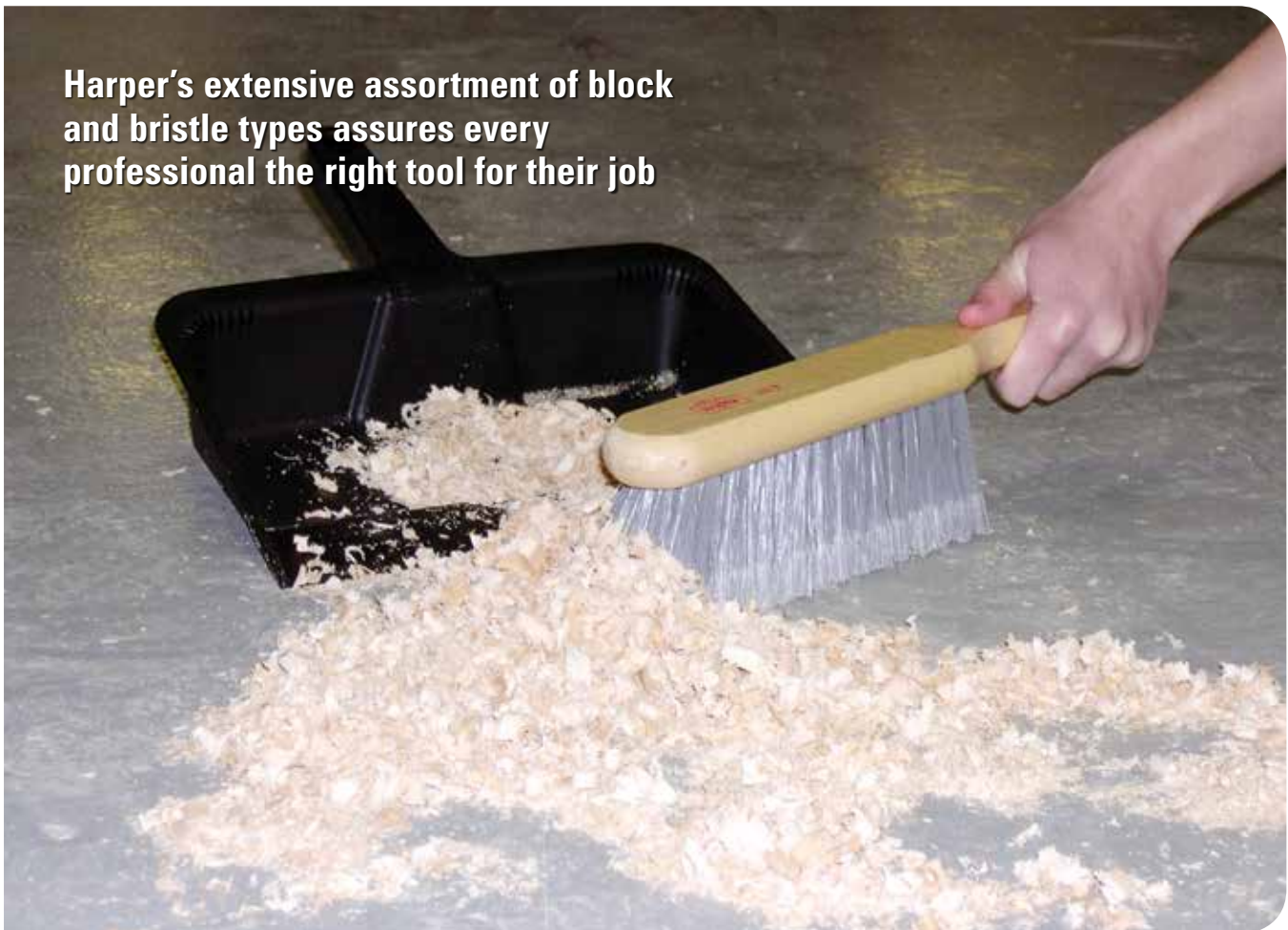

Harper's extensive assortment of block and bristle types assures every professional the right tool for their job

Wet Mops

Mopping is more than a one mop fits all activity. Harper® yarn mops come in a wide variety of styles, sizes and materials. The three primary styles are cut-end, looped-end and screw-on. Sizes are measured in either numbers, ounces or small, medium, large and extra-large (S, M, L, XL). Material options are cotton, rayon, nylon, synthetic blend, or microfiber. Handles are sold separately.

Cotton, Cut-End



Item no.	Description
2008	No. 8 Cotton, cut-end mop
2016	No. 16 Cotton, cut-end mop
2020	No. 20 Cotton, cut-end mop
2024	No. 24 Cotton, cut-end mop
2032	No. 32 Cotton, cut-end mop
201601	No. 16 Cotton, cut-end mop, available packaged with UPC code for retail
202001	No. 20 Cotton, cut-end mop, available packaged with UPC code for retail
202401	No. 24 Cotton, cut-end mop, available packaged with UPC code for retail
202401A	No. 24 Cotton, cut-end mop assembled with 1 1/8" x 54" lacquered wood quick change handle

- 4-ply cotton
- 1 1/4" Headband
- No tailband
- Good absorption and retention

Synthetic Blend, Cut-End



Item no.	Description
8012	No. 12 Synthetic blend, cut-end mop
8016	No. 16 Synthetic blend, cut-end mop
8020	No. 20 Synthetic blend, cut-end mop
8024	No. 24 Synthetic blend, cut-end mop
8032	No. 32 Synthetic blend, cut-end mop

- 4-ply blend
- 1 1/4" Headband
- No tailband
- Excellent absorption and durability

Synthetic Blend, Looped-End

Item no.	Description
160121	Small synthetic blend, looped-end mop
160121-2	Small blue synthetic blend, looped-end mop
160122	Medium synthetic blend, looped-end mop
160122-2	Medium blue synthetic blend, looped-end mop
160123	Large synthetic blend, looped-end mop
160123-2	Large blue synthetic blend, looped-end mop
160124	Extra large synthetic blend, looped-end mop
160124-2	Extra large blue synthetic blend, looped-end mop
160201-2	Medium blue synthetic blend, looped-end mop, packaged with UPC code for retail



160122-2



160123

160124

- 4-ply blend
- 1 1/4" Headband
- Tailband for tangle-free use
- Excellent absorption and durability

Item no.	Description
160125	Small synthetic blend, looped-end mop
160126	Medium synthetic blend, looped-end mop
160126-2	Medium blue synthetic blend, looped-end mop
160127	Large synthetic blend, looped-end mop
160127-2	Large blue synthetic blend, looped-end mop
160128	Extra large synthetic blend, looped-end mop
160128-2	Extra large blue synthetic blend, looped-end mop
160301-2	Large, blue synthetic blend, looped-end mop, packaged with UPC code for retail



160126

- 4-ply blend
- 5" Headband
- Extra wide band can be used as a scrubber
- Tailband for tangle-free use



Cotton, Cut-End

Item no.	Description
D7010	No. 10 cotton, cut-end mop
7012	No. 12 cotton, cut-end mop, packaged with UPC code for retail
D7012	No. 12 cotton, cut-end mop
7016	No. 16 cotton, cut-end mop, packaged with UPC code for retail
D7016	No. 16 cotton, cut-end mop
7024	No. 24 cotton, cut-end mop, packaged with UPC code for retail
D7024	No. 24 cotton, cut-end mop

- 4-ply cotton
- Wire-bound construction
- 7/8" x 48" Handle
- Good absorption and retention

Synthetic, Cut-End



Item no.	Description
D7508	No. 8 synthetic, cut-end mop
D7510	No. 10 synthetic, cut-end mop
D7512	No. 12 synthetic, cut-end mop
D7516	No. 16 synthetic, cut-End mop

- 4-ply rayon
- Wire-bound construction
- 15/16" x 54" Handle
- Excellent absorption

Twist n' Clean



Item no.	Description
300	Twist n' Clean mop, packaged with UPC code for retail
300R	Twist n' Clean mop Refill

- Cotton, with tailbands for tangle-free use
- Non-abrasive scrubber tip
- 15/16" x 54" Handle

Terry Cloth

Item no.	Description
301	3-in-1 floor mop
301R	3-in-1 floor mop refill

- Use wet for quick and easy mopping
- Terry cloth cover is machine washable
- Plastic frame with 60" metal handle



Mops - Sponge

Item no.	Description
H303	9" Large butterfly mop
303R	9" Large butterfly mop refill

- 48" Coated metal handle
- Cellulose sponge
- Metal wringer with steel rod



Item no.	Description
308	9 1/2" Household roller mop
308R	9 1/2" Household roller mop refill

- 48" Coated metal handle
- Synthetic sponge
- Plastic casing with two brush strips



Item no.	Description
311	10" PVA roller mop
311R	10" PVA roller mop refill

- 48" Coated metal handle
- PVA sponge
- Plastic casing , metal rod



Mops - Sponge

6013



Item no.	Description
6013	12" Jumbo roller mop, packaged with UPC code for retail
6113	12" Jumbo roller mop refill

- 48" Coated metal red handle
- Cellulose sponge
- Metal casing

99078



Item no.	Description
99078	8 1/2" Deluxe squeeze mop
99078R	8 1/2" Deluxe squeeze mop refill

- 48" Coated metal handle
- Cellulose sponge
- Metal wringer with rubberized grip

A variety of mops for homes, offices and professional food service cleaning

Mop Buckets and Handles

Wringer Buckets

Item no.	Description
HC0080YE	26 qt. Mop bucket with sidepress wringer

- Accommodates a 12 oz. to 32 oz. mop head
- Ideal for small businesses, restaurants, home use, etc



Item no.	Description
HC0070YE	35 qt. Mop bucket with sidepress wringer

- Accommodates a 12 oz. to 32 oz. mop head
- Durable plastic construction ideal for all commercial settings



Wet Mop Handles

Item no.	Description
540S	54" Wet mop handle

- 1 1/8" Wood construction
- Sanded and lacquered
- Metal spring and lever hardware



Item no.	Description
540WQM	54" Wet mop handle

- 1" Coated metal construction
- Metal quick-change hardware
- Lightweight



Wet Mop Handles

54054H



Item no.	Description
54054H	54" Wet mop handle
54060H	60" Wet mop handle

- 15/16" Wood mop stick
- Sanded and lacquered
- Plastic quick-bite hardware

54054HM-7



Item no.	Description
54054HM-7	54" Wet mop handle
54060HM-7	60" Wet mop handle

- 15/16" Metal mop stick
- Plastic quick-bite hardware

540WQ



Item no.	Description
540WQ	54" Wet mop handle
273H	54" Wet mop handle with blue painted tip
273HR	54" Wet mop handle with red painted tip

- 1 1/8" Wood construction
- Sanded and lacquered
- Metal quick-change hardware

54054HFG-2



Item no.	Description
54054HFG-2	54" Blue wet mop handle
54060HFG-2	60" Blue wet mop handle

- 1" Fiberglass construction
- Plastic quick-bite hardware
- Ideal for use in food service applications

Dust Mops

Handles and frames are sold separately.

Item no.	Description
DM518	18" Premium cotton dust mop
DM524	24" Premium cotton dust mop
DM536	36" Premium cotton dust mop

- Cut end
- Fabric back with snap closures
- Fits 5" metal frames



Item no.	Description
40601	24" Premium cotton dust mop, packaged with UPC code for retail
40601A	24" Premium cotton dust mop assembled with 24" x 5" metal frame and 15/16" x 60" wood handle with metal swivel quick release connector
40618	18" Premium cotton dust mop
40624	24" Premium cotton dust mop
40636	36" Premium cotton dust mop
40648	48" Premium cotton dust mop
40660	60" Premium cotton dust mop

- Looped end
- Fabric back with snap closures
- Fits 5" metal frames



Wire Frames

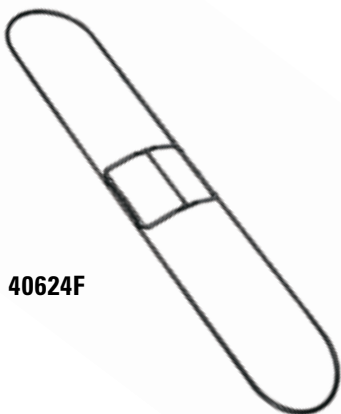

40624F

Item no.	Description
40618F	18" Metal frame for dust mops
40624F	24" Metal frame for dust mops
40636F	36" Metal frame for dust mops
40648F	48" Metal frame for dust mops
40660F	60" Metal frame for dust mops

- 5" Wide
- For use with quick release handles

Handles Dust Mop



Item no.	Description
40660H	60" Dust mop handle, standard pk of 12

- 1 1/8" Wood construction
- Sanded and lacquered
- Quick release connector for metal dust mop frames
- Metal connector swivels for ease of use



Good absorption and water retention for efficient cleaning done right the first time

Whether you've got a large area such as an airplane, or the awkward space of an automobile interior, Harper® has what it takes to get the job done. Built for the toughest grime, but yet soft enough to use on the finest of finishes, Harper's® wash brushes are different than other brushes in that they are made to retain water, and will hold up when immersed for hours. Harper® also has brushes developed for washing trucks with strong acid solution.

All Purpose Wash Brushes

Item no.	Description
685508	8" Plastic block with vinyl protective bumper
685508X	8" Plastic block
685510	10" Plastic block with vinyl protective bumper
685510X	10" Plastic block

- Soft, split-tip nylon bristles, 2 1/2" trim length
- Provides non-scratch performance and maximum liquid retention
- Ideal for automotive and marine applications



Item no.	Description
686410X	10" Plastic block

- Split-tip, acid-resistant synthetic bristles, 2 1/2" trim length
- Extremely durable
- Ideal for heavy-duty use in areas such as: fertilizer plants, kennels, anhydrous ammonia plants and recreational departments



Item no.	Description
686508	8" Plastic block with vinyl protective bumper
686508X	8" Plastic block
686510	10" Plastic block with vinyl protective bumper
686510X	10" Plastic block

- Split-tip, acid-resistant tampyl bristles, 2 1/2" trim length
- Extremely durable
- Ideal for cement contractors, cement trucks and use with strong acid solutions



All Purpose Wash Brushes



Item no.	Description
686608	8" Plastic block with vinyl protective bumper
686610	10" Plastic block with vinyl protective bumper
686614	14" Plastic block

- Soft, split-tip nylon bristles, 2 1/2" trim length
- Provides non-scratch performance and maximum liquid retention
- Ideal for automotive and marine applications



Item no.	Description
687310	10" Plastic block with vinyl bumper
687310A	10" Plastic block with vinyl bumper assembled with 15/16" x 54" metal handle, packaged with UPC code for retail

- Split-tip synthetic bristles, 2 1/2" trim length
- Extremely durable
- Ideal for heavy-duty use in areas such as: trucking companies, construction sites, farms, grain elevators and recreational departments

Tri-Level All Purpose Wash Brushes



Item no.	Description
885510	10" Plastic tri-level block

- Soft, split-tip nylon bristles, 2 1/2" trim length
- Block and bristles design allow for three distinct washing angles
- Structural resin block, threaded handle hole
- Ideal for automotive and marine applications



Item no.	Description
885510-W	10" Plastic tri-level block with filled ends

- Soft, split-tip nylon bristles, 2 1/2" trim length
- Plastic block ends are not exposed, reducing the possibility of scratching
- Structural resin block, threaded handle hole
- Ideal for washing grills and wheel rims

Item no.	Description
886510	10" Plastic tri-level block

- Split-tip, acid-resistant tampyl bristles, 2 1/2" trim length
- Block and bristles design allow for three distinct washing angles
- Structural resin block, threaded handle hole
- Ideal for cement contractors washing trucks in strong acid solutions



Item no.	Description
887310	10" Plastic tri-level block
887310A	10" Assembled plastic tri-level block with 15/16" x 54" metal handle

- Split-tip synthetic bristles, 2 1/2" trim length
- Block and bristles design allow for three distinct washing angles
- Structural resin block, threaded handle hole
- Ideal for heavy-duty use in areas such as: trucking companies, farms, grain elevators and recreational departments



Specialty Wash Brushes

Item no.	Description
H356	4 1/4" Wheel brush

- Split-tip synthetic bristles, 3 1/4" trim length
- Flow-through plastic block with threaded 45° handle hole
- Ideal for cleaning wheels and rims



Specialty Wash Brushes



Item no.	Description
695508V	8" Wash brush
695510V	10" Wash brush

- Split-tip synthetic bristles, 2 7/8" trim length
- Safe on all surfaces
- Bristles feature maximum liquid retention



Item no.	Description
895510V	10" Bi-Level wash brushes with distinct washing angles

- Split-tip synthetic bristles, 2 7/8" trim length
- Safe on all surfaces
- Bristles feature maximum liquid retention



Item no.	Description
H561	Nylon detail brush
H563	Stainless steel detail brush

- Quality nylon or steel bristles, 1/2" trim length
- Plastic toothbrush-style handle, 7 1/4" overall length
- Ideal for cleaning small, hard-to-reach areas in a variety of applications



Item no.	Description
566	7" Detail brush kit, 3-pack

- Synthetic, stainless steel and brass bristles, 1/2" trim length
- Wood toothbrush-style handle 7" overall length
- Ideal for cleaning small, hard-to-reach areas in a variety of applications



Item no.	Description
H574	8 1/4" Tire and wheel brush

- Crimped synthetic bristles, 1/2" trim length
- Quality resin block, with hang up hole
- Ideal for cleaning tire sidewalls and rims

Vehicle Cleaning Accessories

Item no.	Description
530	11 1/2" Whisk broom

- 100% Broom corn bristles
- 2-sew
- Metal cap
- Hanging ring



Item no.	Description
20508	8" Windshield squeegee
20710	10" Windshield squeegee

- Rubber squeegee combined with net-covered sponge
- Threaded handle socket
- Handle #20720H sold separately



Item no.	Description
20808	8" Windshield squeegee

- Rubber squeegee combined with net-covered sponge
- Plastic head and handle
- Handle is 20" in length



Item no.	Description
448	Microfiber chamois

- Absorbs eight times its weight in water
- Microfiber Size: 28" x 38"



Item no.	Description
36460H	60" Flow-through handle

- Metal with hose connection on one end, threaded on the other
- Flow-through construction
- 1" diameter



Microfiber Cloths

T843



Item no.	Description
T843	16" x 16" Microfiber cleaning cloth, 1 pack
T843BP	16" x 16" Microfiber cleaning cloth, Bulk Pack (250)

- Grid pattern weave for tough cleaning jobs
- Little or no chemicals needed
- Washable and reusable

T844



Item no.	Description
T844	16" x 16" Microfiber glass & mirror cloth, 1 pack
T844BP	16" x 16" Microfiber glass & mirror cloth, Bulk Pack (250)

- Extra fine microfiber weave for streak free cleaning
- Washable and reusable

T845



Item no.	Description
T845	16" x 16" Microfiber all purpose polishing cloth, 1 pack
T845BP	16" x 16" Microfiber all purpose polishing cloth, Bulk Pack (250)

- Superb for polishing and wax removal
- Washable and reusable

T846



Item no.	Description
T846	16" x 16" Microfiber dusting cloth, 1 pack
T846BP	16" x 16" Microfiber dusting cloth, Bulk Pack (250)

- Cloths collect, capture and hold dust
- Washable and reusable

Microfiber Cloths

Item no.	Description
T847	5" x 14" Microfiber dusting sleeve, 1 pack

- Fits over standard lambs wool or polywool duster
- Washable and reversible
- Residue free



Mitts

Item no.	Description
T848	Green microfiber dusting mitt with thumb

- Cloths collect, capture and hold dust
- One size, fits most
- Tight elastic cuff



Item no.	Description
T849-5	7" X 10" White microfiber chenille super mitt

- Designed for streak free finish
- Elastic wrist band for comfort and secure fit



Accessories

Item no.	Description
86-88	Powder-coated metal, for 88 series tri-level wash brushes



Buckets and Dust Pans

Buckets



Item no.	Description
258-1	14 qt. Red Clean Rinse® plastic double bucket
258-2	14 qt. Blue Clean Rinse® plastic double bucket

- Dual cavities keep rinse water clean
- Tool holder and washboard features
- Packaged with UPC code for retail



Item no.	Description
H268	17 qt. Red Plastic bucket
268-13	17 qt. Gray Plastic bucket

- Easy-pour grip in back of bucket
- Heavy-duty metal bail with plastic grip
- Packaged with UPC code for retail



Item no.	Description
269	19 qt. Red plastic double bucket

- Dual cavities keep rinse water clean
- Heavy-duty metal bail with plastic grip
- Packaged with UPC code for retail

Dustpans

Item no.	Description
478	12" Plastic lobby dust pan

- Snap-locks for use and releases to dump or carry
- Aluminum handle with hang cap for easy storage, 39 1/2" overall length
- Handle clip for broom hanging on maid cart/trash can
- Packaged with UPC code for retail



Item no.	Description
479-8	9" Plastic dust pan

- Raised lip reduces debris spillage
- Clip-on style handle attaches to most brooms



Item no.	Description
H480	12" Black plastic dust pan
480-1	12" Red plastic dust pan
480-2	12" Blue plastic dust pan

- One-piece pan with hang-up hole and rubber lip
- Clip-on style handle attaches to most brooms



Item no.	Description
480-7	12" Plastic dust pan

- One-piece pan with hang-up hole
- 4" Handle
- Packaged with UPC code for retail



Dustpans



Item no.	Description
481-7	12" Metal dust pan

- Heavy duty
- Beveled edge



Item no.	Description
H485	16" Aluminum dust pan

- Heavy-duty yet lightweight
- Rubber grip handle
- 9" Handle



Item no.	Description
H495	16" Heavy-duty metal dust pan

- Pan lays flat without holding it
- 9" Handle

497-1



Item no.	Description
497-1	Jumbo plastic debris pan
497-1P4	Jumbo plastic debris pan, 4 pack

- Snap-locks for use and releases to dump or carry
- 25" Metal handle
- Clip-on handle holder

Waste Containers

Item no.	Description
HC2952BG	8 qt. Beige waste container
HC2952BK	8 qt. Black waste container
HC2952GY	8 qt. Grey waste container
HC2955BG	13 qt. Beige waste container
HC2955BK	13 qt. Black waste container
HC2955GY	13 qt. Grey waste container
HC2956BG	28 qt. Beige waste container
HC2956BK	28 qt. Black waste container
HC2956GY	28 qt. Grey waste container
HC2957BG	41 qt. Beige waste container
HC2957BK	41 qt. Black waste container
HC2957GY	41 qt. Grey waste container



HC2952GY
HC2952BK
HC2952BG

- Rectangular, all-plastic construction with rolled rim
- Designed for convenient desk-side management



Durability, quality and attention to detail – that is the Harper way

Handles and Accessories

84H



Bolt-On Connectors

Item no.	Description
84H	15/16" x 60" Red tipped wood handle
85H	1 1/8" x 60" Red tipped wood handle
85HP	1 1/8" x 60" Wood handle

- Lacquered wood
- Bolt-on metal connector
- Use with Harper® slotted block broom heads

Item no.	Description
248HAS	1 1/8" x 60" Squeegee handle

- Red-tipped, lacquered wood
- For straight floor squeegees

Tapered

248H

2204H-12



Item no.	Description
248H	1 1/8" x 60" Tapered, red tipped, lacquered wood handle
253H	15/16" x 60" Tapered, red tipped, lacquered wood handle
2204H-12	15/16" x 60" Tapered, sanded wood handle
3306	1 1/8" x 54" Tapered, lacquered wood handle
9760H-12	1 1/8" x 60" Tapered, lacquered wood handle

Threaded Metal Tip

90260H



Item no.	Description
90260H	1 1/8" x 60" Wood handle with threaded metal tip
90272H	1 1/8" x 72" Wood handle with threaded metal tip
90296H	1 1/8" x 96" Wood handle with threaded metal tip
902120H	1 1/8" x 120" Wood handle with threaded metal tip

- Sanded, no lacquer

Threaded Metal Tip

Item no.	Description
91248H	15/16" x 48" Wood handle with threaded metal tip
91254H	15/16" x 54" Wood handle with threaded metal tip
91260H	15/16" x 60" Wood handle with threaded metal tip
91272H	15/16" x 72" Wood handle with threaded metal tip

- Lacquered



Item no.	Description
113H	1" x 42" Metal threaded handle

- Angled handle for accessing hard-to-reach areas

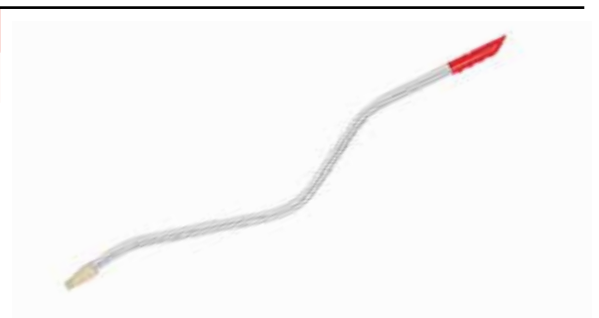

Item no.	Description
116H	7/8" x 48" Red metal handle
116SH	7/8" x 30" Red metal handle
11690	7/8" x 48" Black metal handle

- Threaded end
- Plastic hang-up cap



Item no.	Description
11754H-7	15/16" x 54" Black metal threaded handle
11760h-7	15/16" x 60" Black metal threaded handle

- Reinforced plastic threaded tip
- Metal pin core for added strength



Threaded - Wood Tip



Item no.	Description
20720H	15/16" x 20" Red painted wood handle with threaded wood tip
4402H-12	15/16" x 42" Sanded wood handle with threaded wood tip
4403H-12	15/16" x 54" Wood handle with threaded wood tip
4404	15/16" x 60" Wood handle with threaded wood tip
5507	1 1/8" x 60" Lacquered wood handle with threaded wood tip
90048H	15/16" x 48" Lacquered wood handle with threaded wood tip
90054H	15/16" x 54" Lacquered wood handle with threaded wood tip
90060H	15/16" x 60" Lacquered wood handle with threaded wood tip

Threaded - Plastic Tip



Item no.	Description
90148	15/16" x 48" Wood handle with threaded plastic tip
90148H	15/16" x 48" Wood handle with threaded plastic tip, with hang-up cap
90154H	15/16" x 54" Wood handle with threaded plastic tip
90160H	15/16" x 60" Wood handle with threaded plastic tip
90172H	15/16" x 72" Wood handle with threaded plastic tip
90460H	1 1/8" x 60" Wood handle with threaded plastic tip
90472H	1 1/8" x 72" Wood handle with threaded plastic tip
90496H	1 1/8" x 96" Wood handle with threaded plastic tip

- Lacquered



Item no.	Description
46908-7	1" x 60" Fiberglass handle with threaded plastic tip

Threaded - Acid Resistant Tip

Item no.	Description
91160H	1 1/8" x 60" Handle with acid resistant tip
91172H	1 1/8" x 72" Handle with acid resistant tip
91196H	1 1/8" x 96" Handle with acid resistant tip

- Lacquered wood
- Acid-resistant tip



91160H



**Durability
Pros Rely On**

DSPLY03



Wire Displays

Item no.	Description
DSPLY03	12-Piece Wire Merchandising Rack

- 31" x 22.5" x 24.5"
- Triangular in shape, this powerful merchandiser can accommodate 12 to 14 stick good products. Two wire hooks on the side allow for promotional signage

DSPLY02WW



Item no.	Description
DSPLY02WW	Mobile wire merchandiser rack with grid
DSPLY06	Wire merchandiser rack with grid without wheels

- 36" x 90"
- Wheels make this merchandiser mobile. A wire grid accommodates smaller products, and stops at the base where dust pans can be displayed. Merchandise four feet of linear product in a minimal amount of space

Anatomy of a Harper® Push Broom

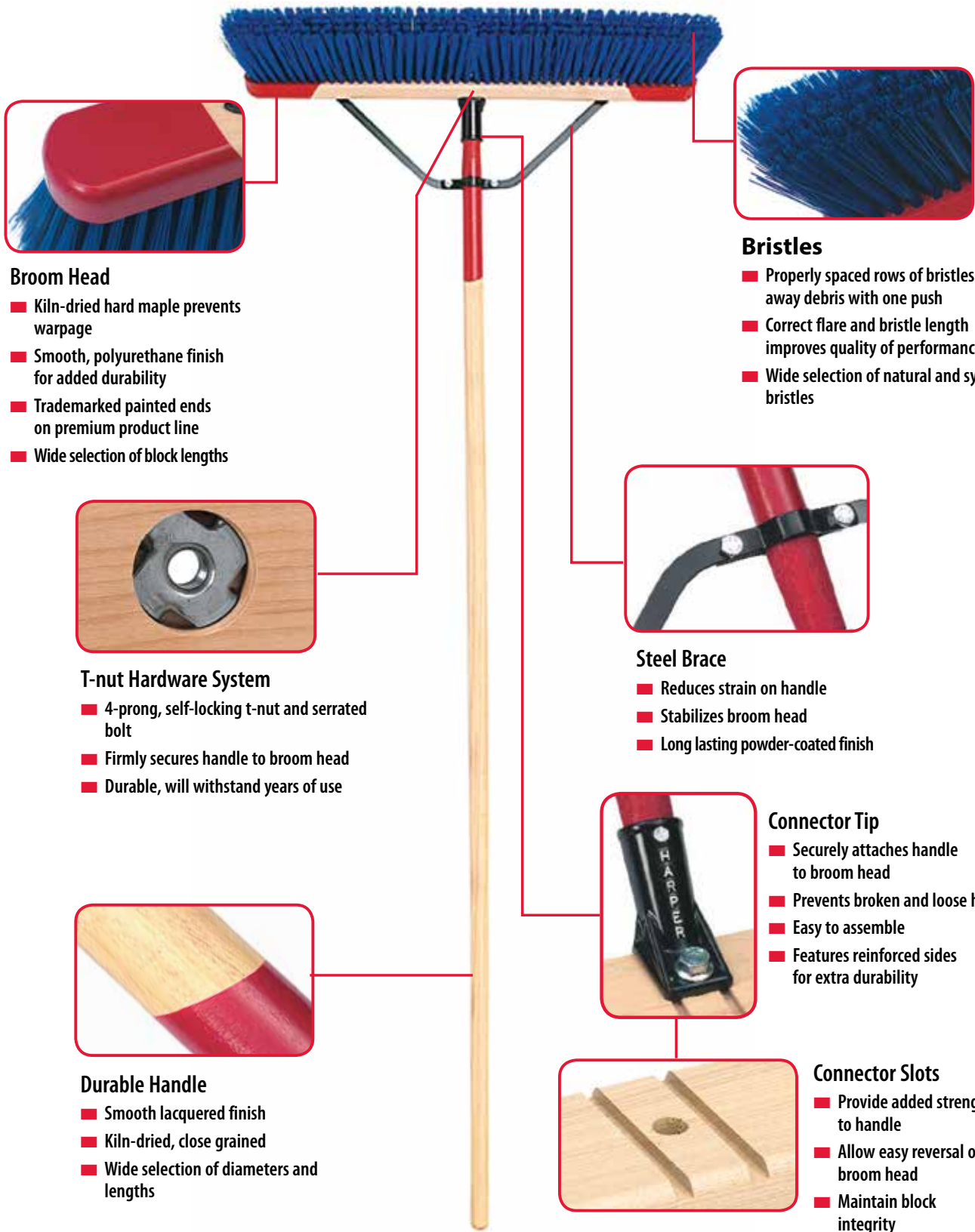

Broom Head

- Kiln-dried hard maple prevents warpage
- Smooth, polyurethane finish for added durability
- Trademarked painted ends on premium product line
- Wide selection of block lengths

Bristles

- Properly spaced rows of bristles sweep away debris with one push
- Correct flare and bristle length improves quality of performance
- Wide selection of natural and synthetic bristles

T-nut Hardware System

- 4-prong, self-locking t-nut and serrated bolt
- Firmly secures handle to broom head
- Durable, will withstand years of use

Steel Brace

- Reduces strain on handle
- Stabilizes broom head
- Long lasting powder-coated finish

Connector Tip

- Securely attaches handle to broom head
- Prevents broken and loose handles
- Easy to assemble
- Features reinforced sides for extra durability

Durable Handle

- Smooth lacquered finish
- Kiln-dried, close grained
- Wide selection of diameters and lengths

Connector Slots

- Provide added strength to handle
- Allow easy reversal of broom head
- Maintain block integrity